

ChE 436: Feedforward Control Exercise

The following feedforward controller (G_{ff}) has been proposed to improve the control of the disturbance (D) with the following transfer functions:

$$G_p(s) = \frac{0.6e^{-37s}}{39s+1} \quad G_d(s) = \frac{0.25e^{-57s}}{31s+1} \quad G_v(s) = \frac{5}{2s+1}$$

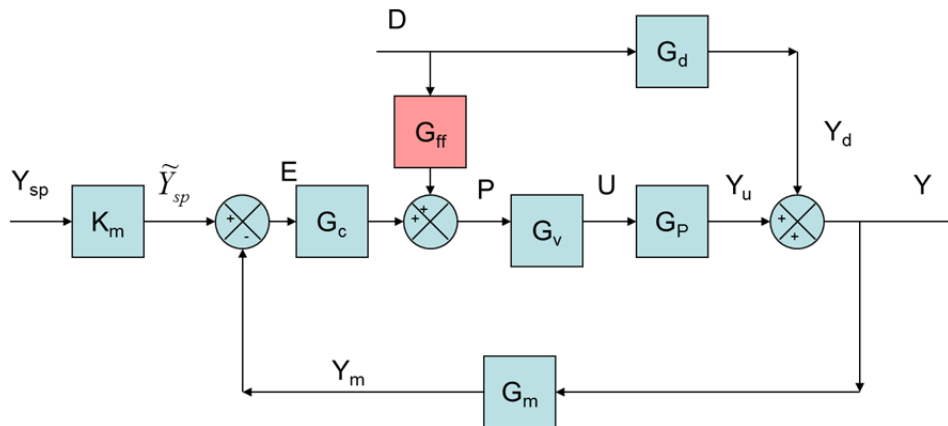

Derive a dynamic and static feedforward controller (G_{ff}) that will best reject the disturbance (D).